

# Motorized Pulley 500H, Ø 500 mm

Motorized Pulley with terminal box

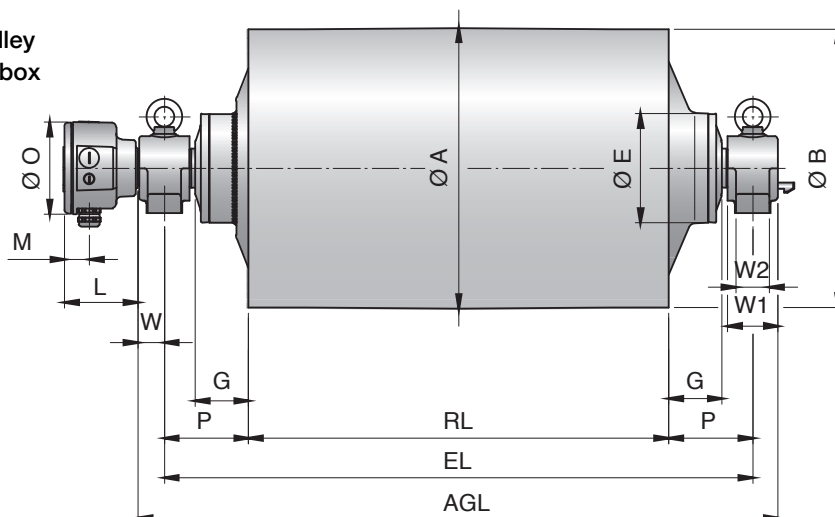

Idler Pulley UT500H

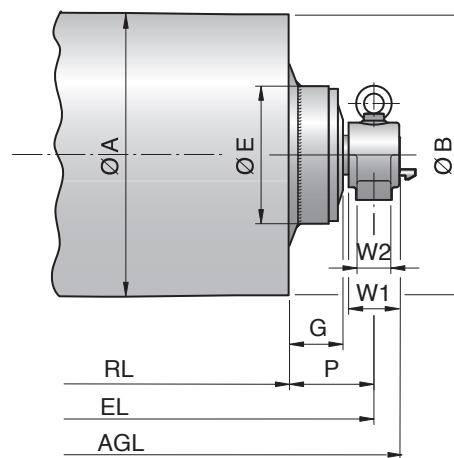

Type	A mm	B mm	C mm	D mm	E mm	G mm	L mm	M mm	O mm	P mm
500H	501	497	-	65	192	95	131	46	165	150
500H (22 & 30kW)	521*	517*	-	65	235	95	166	54	230	150
UT500H	501	497	-	65	235	95	-	-	-	150

\* including ceramic lagging

Mounting bracket AL65 & ALO65

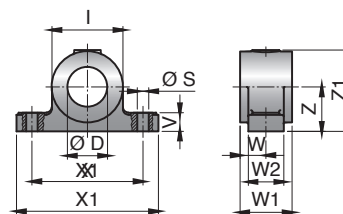

Motorized Pulleys & Idler Pulleys (UT) Type	Material	Bracket description	Dimensions												Weight kg
			D mm	I mm	S mm	V mm	W mm	W1 mm	W2 mm	X mm	X1 mm	Z mm	Z1 mm		
500H & UT500H	Spheroidal cast iron	AL65 / ALO65	65	115	23	34	45	90	60	180	240	80	141	8.0	